

IT	Manuale d'istruzioni Piano di cottura da incasso	4
GB	User and installation instructions Built-in hob	10
FR	Conseils d'utilisation et d'installation Table de cuisson encastrable	16
DE	Gebrauchs- und Installationsanleitungen Einbau-Gasmulde	22
ES	Instrucciones para el uso e instalación Placa de cocción empotrable	28
PT	Instruções de utilização e instalação Placa de encastrar	34
GR	Οδηγίες χρήσης και εγκατάστασης Εντοιχιζόμενη μονάδα εστιών	40
TR	Kullanım ve kurulum için talimatlar Ankastre Ocak	46
RU	Инструкции по установке и эксплуатации Встраиваемая варочная панель	52
RO	Manual de instrucțiuni Plită de gătit cu încorporare	58
PL	Instrukcja obsługi Płyta kuchenna do zabudowy	64

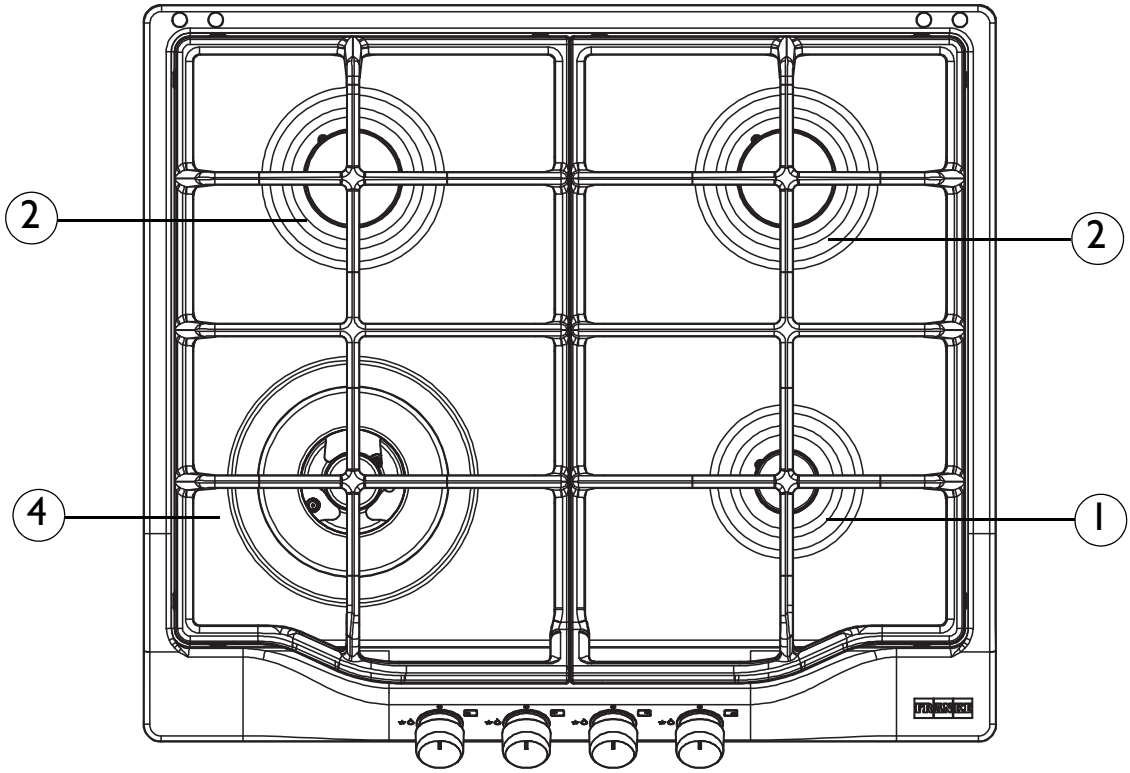

Fig. 1a

FHTL 604 3G TC

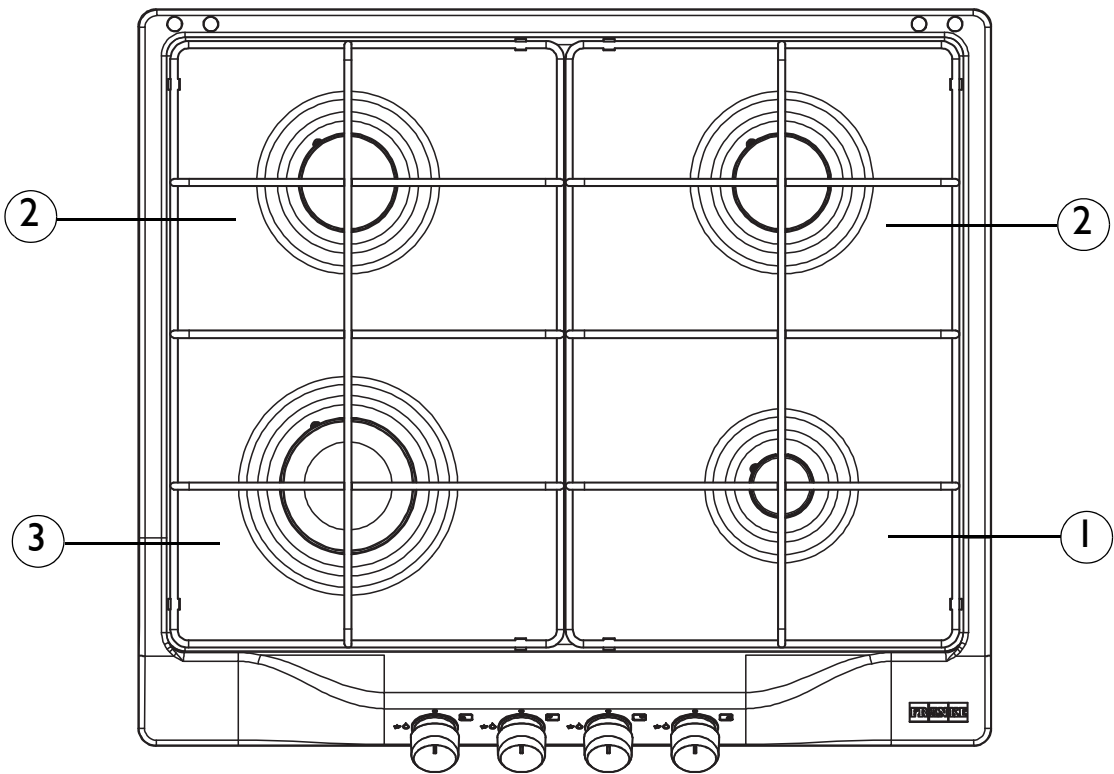

Fig. 1b

FHTL 604 4G

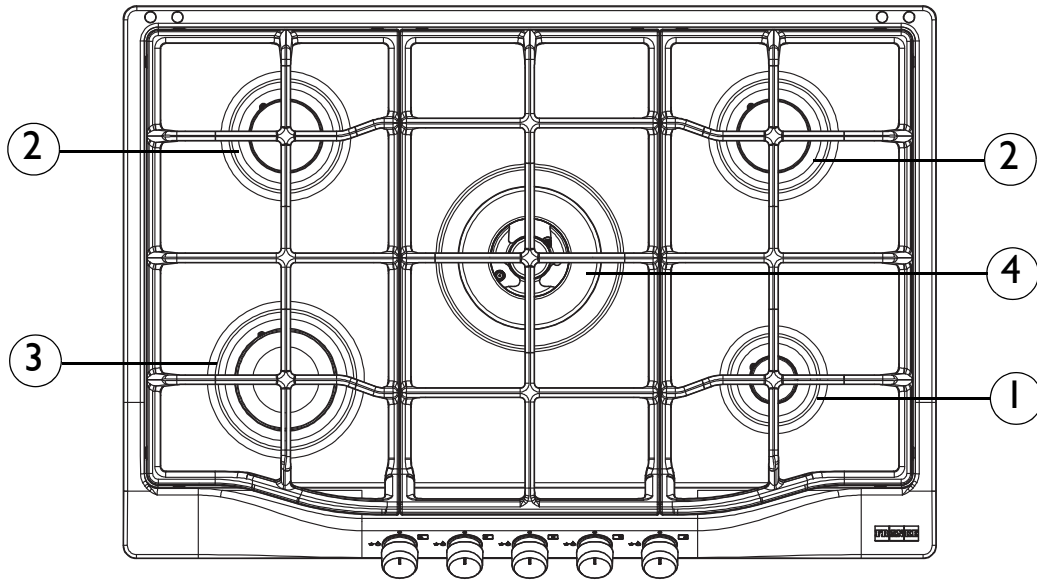

Fig. 1c

FHTL 755 4G TC

<p>IT</p> <p>1) ausiliario 2) semirapido 3) rapido 4) tripla</p>	<p>GB</p> <p>1) auxiliary 2) semi-rapid 3) rapid 4) triple crown</p>	<p>FR</p> <p>1) auxiliaire 2) semi-rapide 3) rapide 4) triple couronne</p>	<p>DE</p> <p>1) Zusatzbrenner 2) Normalbrenner 3) Schnellbrenner 4) Dreifacher</p>	<p>ES</p> <p>1) auxiliar 2) semirrápido 3) rápido 4) triple corona</p>	<p>PT</p> <p>1) auxiliar 2) semi-rápido 3) rápido 4) tripla coroa</p>
<p>GR</p> <p>1) Βοηθητική 2) Ημιταχεία 3) Ταχεία 4) Τριπλή κορόνα</p>	<p>TR</p> <p>1) Yardımcı 2) Yarı hızlı 3) Hızlı 4) Üç bilezikli</p>	<p>RU</p> <p>1) Вспомогательная 2) Ускоренного действия 3) Быстродействующая 4) Тройная корона</p>	<p>RO</p> <p>1) Auxiliar 2) Semirapid 3) Rapid 4) Triplă coroaă</p>	<p>PL</p> <p>1) pomocniczy 2) średniej mocy 3) dużej mocy 4) potrójny</p>	

Fig. 2a/2b/2c/2d

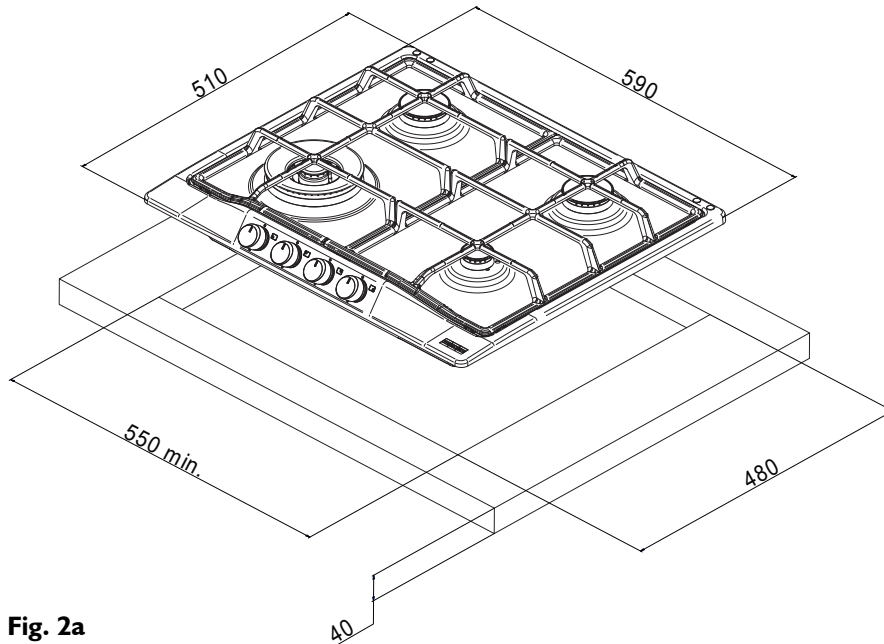

Fig. 2a

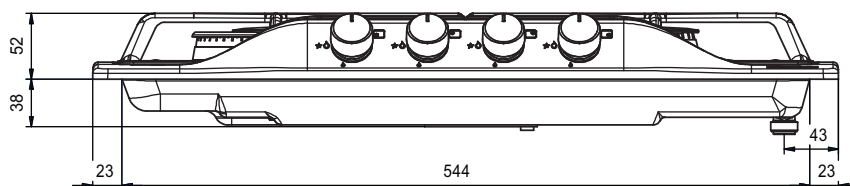

Fig. 2b

FHTL 604 3G TC
FHTL 604 4G

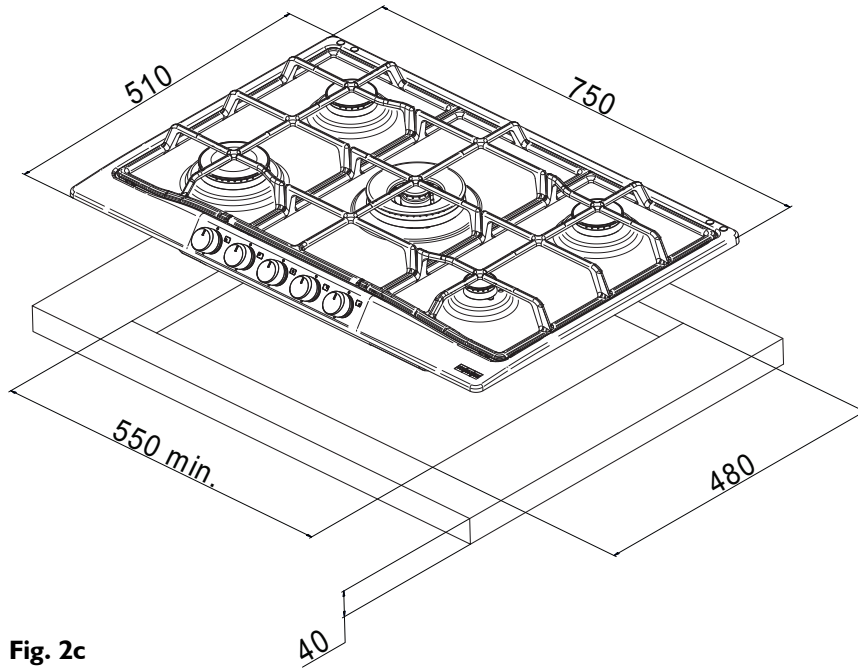

Fig. 2c

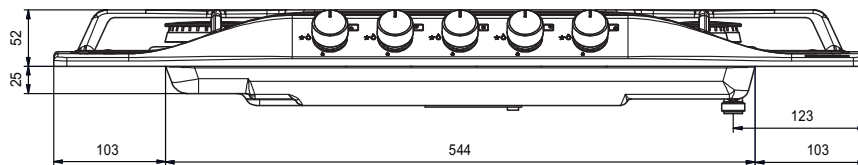

Fig. 2d

FHTL 755 4G TC

Fig. 3 / Fig. 4

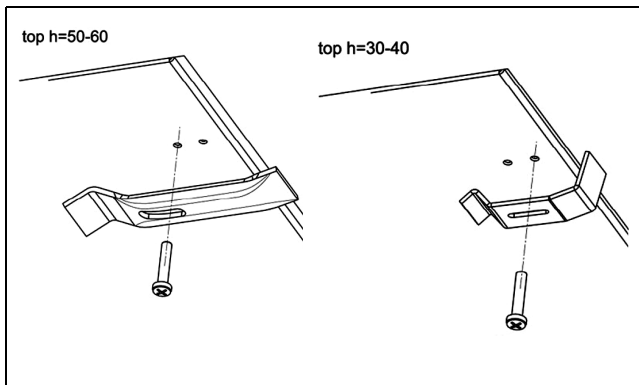

Fig. 3

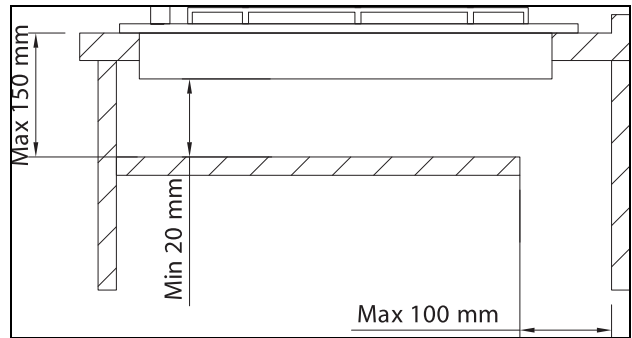

Fig. 4

Contents

Introduction.....	10
Use	10
Hob cleaning and maintenance.....	10
Support.....	11
Safety instructions.....	11
Installation.....	12
Technical Data.....	14

Introduction

Thank you for choosing a Franke product. Before using the appliance, please read all the instructions and advice contained in this manual. In this way you will be able to make best use of the appliance and also ensure its lasting efficiency. Keep this booklet for further reference.

Use

Lighting the burners

In these models lighting is done with the knobs. To light the burners, proceed as follows:

1. Press and turn the required knob.
2. Keep the knob pressed down for 3-4 seconds to allow the sparks to ignite the gas coming out the flame spreader and to allow the thermocouple to heat up.
3. Then release the knob and, turning it anticlockwise (in models 604 and 1204, to the lighting symbol *), adjust the flame as required. If the flame does not stay alight, repeat the operations from step 1.

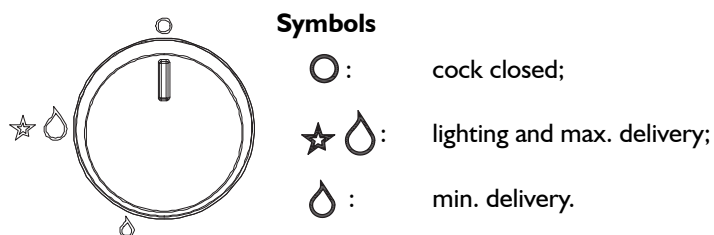

Burner use

For lower gas consumption and better efficiency, it is advisable to use pots of widths suitable for the burners, making sure the flame does not go beyond the edges (comply with the table on page 14).

Automatic safety valve

These hobs have a safety device that automatically closes the gas cock if the flame accidentally goes out due to draughts, a pot spilling over, or a temporary interruption of the gas supply. This device is activated approx. 30 seconds after the flame goes out.

Hob cleaning and maintenance

Before carrying out any hob cleaning or maintenance, always unplug the appliance or disconnect the power by means of the main switch.

- Never use steam appliances, scouring pads, steel wool, muriatic acid or other products which could scratch or mark the surface.
- Do not leave acid or alkaline substances on the hob.
- Never use sharp objects, as they could damage the seals between the trim and worktop.
- Do not use products containing sands, alkalis, acids, chlorides, oven sprays or detergents normally used to clean dishwashers.
- To prevent scale deposits from forming, always thoroughly dry the appliance after going over it with a damp cloth.
- Immediately remove any foods with high sugar content that spill onto the hob.
- Remove grime with a damp cloth.

- All the grates, burner caps and flame-spreaders can be cleaned (after removing them from the hob) with hot soapy water, making sure to carefully dry them. **DO NOT CLEAN IN A DISHWASHER.** Make sure the gas outlet zones are perfectly clean.
- The natural colour of the pot grids in the pot placing section may alter over time due to the heat.

Support

In case of any operation problems, contact the Franke Technical Service Centre (see attached list).

Never make use of unauthorised technicians.

Specify:

- the type of fault;
- the appliance model (Art.);
- the serial number (S.N.).

This information is given on the appliance dataplate on the warranty certificate.

Safety instructions

- This appliance is not intended for use by persons (including children) with reduced physical, sensory or mental capabilities, or lack of experience and knowledge, unless they have been given supervision or instructions concerning the use of the appliance by a person responsible for their safety.
- Children must be supervised to ensure that they do not play with the appliance.
- The manufacturer declines any liability for damage due to: incorrect installation, improper, wrong or unreasonable use.

Always contact qualified personnel in the following cases:

- installation (refer to the installation section);
- doubts regarding operation.

Contact an authorised service centre in the following cases:

- immediately after unpacking, in case of doubts about the integrity of the appliance;
- replacing or damaged power cable;
- appliance malfunction or poor operation, requesting original spare parts.

General instructions

To ensure safe and efficient operation of this appliance:

- only contact authorised service centres;
- always demand the use of original spare parts;
- the appliance is designed for non-professional, domestic use; do not modify its characteristics;
- the dataplate gives the symbols indicating the countries for which the instructions apply;
- appliance electrical safety is guaranteed only when it is connected to an earthing system in compliance with the current regulations;
- this appliance is not intended for use by persons (including children) with reduced physical, sensory or mental capabilities, or lack of experience and knowledge, unless they have been given supervision or instructions concerning the use of the appliance by a person responsible for their safety;
- **do not touch the pot grids during use, since they become very hot. Keep children away from the appliance;**
- only use the appliance for cooking food;
- before any cleaning or maintenance operations, or in case of malfunction, disconnect the appliance from the mains power supply;
- always check that the control knobs are in the off position when the appliance is not in use.

Do not allow children to touch:

- the controls or the appliance in general;
- the packing elements (bags, polystyrene, staples, etc.);
- the appliance, during and immediately after use, since the hob becomes very hot;
- an unused appliance (make any potentially hazardous parts safe).

Do not:

- touch the appliance with wet parts of the body;
- use the appliance when barefoot;
- pull the appliance or power cable to unplug it;
- carry out improper or hazardous operations;
- leave the power cables of other electric appliances on hot parts of the appliance;
- expose the appliance to atmospheric agents;
- use the appliance as a support top;

- use flammable liquids near the appliance;
- use adapters, multi-sockets or extension leads;
- allow anyone except qualified personnel to install or repair the appliance.

Important

- Do not place unstable or deformed pots on the burners, since they may tip over or cause spills.
- If the appliance has a lid, make sure the burners are cold before closing it.
- Close the gas supply cock when the hob is not in use.
- Before installation, make sure the gas supply is compatible with appliance specifications. The type of gas for which the appliance is arranged is specified on the dataplate on the bottom of the tray. This appliance is not connected to a fume extraction device and must be installed and connected in compliance with the current regulations. Pay particular attention to the applicable regulations on ventilation. The use of a gas cooking appliance produces heat and humidity in the room where it is installed. Ensure the room is adequately ventilated: keep natural ventilation openings open, or install a mechanical ventilation device (extractor hood with exhaust duct). In case of intensive or prolonged use of the appliance, it may be necessary to provide additional ventilation, for example by opening a window, or more efficient ventilation, by increasing the fan speed (if present).

Installation

The necessary operations for installation, including gas and electrical connections, are described below. They must be carried out by qualified personnel in accordance with current regulations, since their performance by unskilled persons may constitute a hazard.

The manufacturer declines any liability for injury to persons or damage to things due to failure non-compliance with these provisions. The gas connection must comply with the regulations in force in the country at the time of installation.

Preparing the cabinet

This handbook refers to a class 3 built-in hob.

Prepare the hole in the top according to the measurements given in fig. 2.

In any case, it is essential to make the opening in the most convenient position, bearing in mind that the gas pipe must not come into contact with the sides of any oven under the hob.

Fitting in the cabinet

After carrying out the connection operations, apply the sealing strip around the hole and position the hob.

Carefully tighten the fixing hooks (fig. 3). Remove any excess sealing strip.

Note

If the appliance is not installed above an oven, a separator baffle must be arranged (fig. 4).

Connection to the gas supply

Connect the appliance to the gas supply in compliance with the current regulations, only after making sure it is arranged for the type of gas to be used.

Otherwise, carry out the operations described in the section on “replacing injectors” (page 13). For liquid gas use pressure regulators complying with the current regulations.

Connection to the gas supply can be made in two ways:

- Connect the gas hob using a 12 mm diameter rigid copper pipe, as shown in fig. 5. To ensure a good seal, use the elastomer gasket supplied as an accessory.
- Connect the hob using a continuous-surface flexible steel tube. Also in this case, to ensure a good seal use the gasket supplied as an accessory. Make sure to comply with the current regulations on gas systems.

After carrying out the connection use soapy water to check for any leaks.

For United Kingdom, Northern Ireland and Republic of Ireland

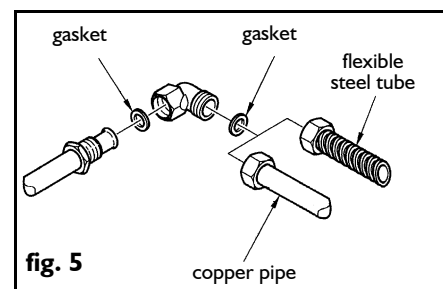
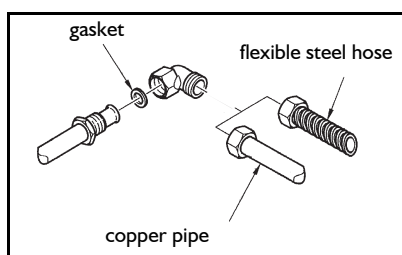

Ventilation of rooms

Make sure the room where the appliance is installed has permanent ventilation openings towards the outside or ventilation ducts to ensure an adequate air flow, as prescribed by the current regulations. All openings made must:

1. have a section of at least 100 cm²;
2. be made in such a way that they cannot be obstructed from inside or outside;
3. be provided with suitable protection to ensure that the ventilation opening is not reduced;
4. be at a suitable height from floor so that they do not hinder the exhausting of fumes.

If openings are made in the wall of an adjacent room, the latter must have direct ventilation and must not be:

1. a bedroom
2. a common area of the building
3. a fire hazard area

Before testing and inspecting the appliance, make sure the room in which the ventilation opening is made does not have low pressure due to the operation of another user and that the ventilation between the two rooms is guaranteed by permanent free openings, for example by increasing the gap between the bottom of the door and the floor. The exhausting of fumes must occur by means of a hood which, in turn, must be connected to a chimney, flue, or directly to the outside.

Accessing the hob

To access the tray containing the functional parts, proceed as follows:

- remove the grids, burner caps and flame-spreaders;
- remove the knobs, sliding them off their pins;
- remove the screws that fix the burners to the hob;
- lift the hob.

Connection to the power supply

The FRANKE cooking hob comes with a 3-core power cable with free terminals.

If the hob is permanently connected to the power supply, install a circuit breaker having a contact opening distance that allows complete disconnection in the conditions of overvoltage category III. Make sure:

- a) the plug and socket are suitable for a 16 A current;
- b) both are easily accessible and positioned so that no live part can be accessed when inserting or removing the plug;
- c) the plug can be inserted without difficulty and is accessible with the appliance installed;
- d) that when the plug is inserted, the hob is not resting on it when installed in the cabinet;
- e) the terminals of two appliances are not connected to the same plug;
- f) a 3 x 0.5 mm² H05VV-F type cable is used when replacing the power cable;
- g) to respect the polarities of the free terminals (Brown=Live – Blue=Neutral – Yellow/Green=Earth).

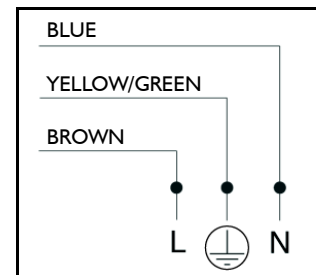

NB: Make sure the characteristics of your household electrical power supply (voltage, maximum output and current) are compatible with those of your FRANKE hob.

Replacing injectors

Important: all the appliances are factory-set for natural gas (G20).

If a different type of gas is to be used, change the injectors as follows:

1. remove the grids, burner caps and flame-spreaders;
2. unscrew the injectors and replace them with those provided and suitable for the gas supply, making sure the marking matches that given in the table (page 14);
3. refit the flame-spreaders, burner caps and grids;
4. these burners do not require air adjustment.

Important

When converting the appliance to a different type of gas, place the corresponding sticker (supplied as an accessory) in the special space on the dataplate. For operation with LPG. (G30 or G31), the minimum flame adjustment screw must be fully screwed down. These appliances are supplied in cat. II 2H3+.

Minimum flame adjustment

- Remove the knobs (push-on type).
- Light the burners and adjust the minimum flame by turning the adjustment screw clockwise to decrease the flame and anticlockwise to increase it (fig. 6). The screwdriver for adjustment is supplied with the accessories.

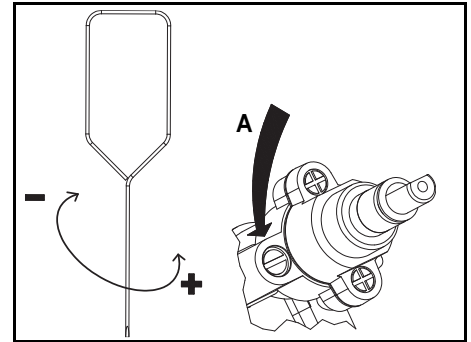

Technical Data

Technical data		FHTL 604 3G TC					
Appliance category:		II 2H3+ (G20=20 mbar >> G30/G31=28-30/37 mbar)					
BURNERS	RATED POWER (kW)	REDUCED POWER (kW)	RATED CAPACITY G20 (m³/h)	G20 INJECTORS 20 mbar (100/mm)	RATED CAPACITY G30/G31 (g/h)	INJECTORS G30/G31 28-30/37 mbar (100/mm)	MAX RECOMMENDED POT Ø (mm)
Auxiliary	1.00	0.55	0.095	77	73	50	140
Semi-rapid	1.75	0.70	0.167	118	127	66	200
Triple crown	3.80	2.10	0.362	141	277	98	240
TOTAL INSTALLED GAS RATED POWER (kW)					8.30		
TOTAL RATED CAPACITY - GAS G20 (m³/h)					0.791		
TOTAL RATED CAPACITY - GAS G30/G31 (g/h)					604		
POWER / VOLTAGE / CURRENT / FREQUENCY					0.6 W / 220-240 V / 16 A / 50-60 Hz		
AIR NECESSARY FOR COMBUSTION (2 m³/h per kW of installed gas rated power)							16.60

Technical data		FHTL 604 4G					
Appliance category:		II 2H3+ (G20=20 mbar >> G30/G31=28-30/37 mbar)					
BURNERS	RATED POWER (kW)	REDUCED POWER (kW)	RATED CAPACITY G20 (m³/h)	G20 INJECTORS 20 mbar (100/mm)	RATED CAPACITY G30/G31 (g/h)	INJECTORS G30/G31 28-30/37 mbar (100/mm)	MAX RECOMMENDED POT Ø (mm)
Auxiliary	1.00	0.55	0.095	77	73	50	140
Semi-rapid	1.75	0.70	0.167	118	127	66	200
Rapid	3.00	1.10	0.286	129	218	85	220
TOTAL INSTALLED GAS RATED POWER (kW)					7.50		
TOTAL RATED CAPACITY - GAS G20 (m³/h)					0.715		
TOTAL RATED CAPACITY - GAS G30/G31 (g/h)					545		
POWER / VOLTAGE / CURRENT / FREQUENCY					0.6 W / 220-240 V / 16 A / 50-60 Hz		
AIR NECESSARY FOR COMBUSTION (2 m³/h per kW of installed gas rated power)							15.00

Technical data		FHTL 755 4G TC					
Appliance category:		II 2H3+ (G20=20 mbar >> G30/G31=28-30/37 mbar)					
BURNERS	RATED POWER (kW)	REDUCED POWER (kW)	RATED CAPACITY G20 (m ³ /h)	G20 INJECTORS 20 mbar (100/mm)	RATED CAPACITY G30/G31 (g/h)	INJECTORS G30/G31 28-30/37 mbar (100/mm)	MAX RECOMMENDED POT Ø (mm)
Auxiliary	1.00	0.55	0.095	77	73	50	140
Semi-rapid	1.75	0.70	0.167	118	127	66	200
Rapid	3.00	1.10	0.286	129	218	85	220
Triple crown	3.80	2.10	0.362	141	277	98	240
TOTAL INSTALLED GAS RATED POWER (kW)					11.30		
TOTAL RATED CAPACITY - GAS G20 (m ³ /h)					1.077		
TOTAL RATED CAPACITY - GAS G30/G31 (g/h)					822		
POWER / VOLTAGE / CURRENT / FREQUENCY					0.6 W / 220-240 V / 16 A / 50-60 Hz		
AIR NECESSARY FOR COMBUSTION (2 m ³ /h per kW of installed gas rated power)							22.60

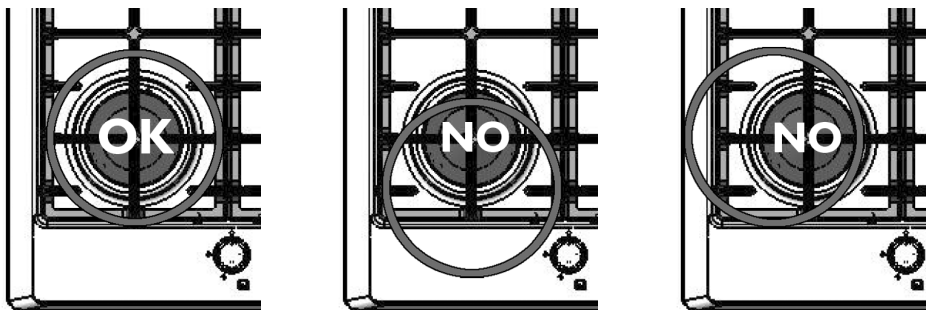

The use of larger pots than those specified can cause excessive overheating of the knobs and top and, in case of prolonged use, yellowing of the cover (if in stainless steel).

Franke declines any liability for damage due to such use.

Total heat capacity: see dataplate on the bottom of the hob.

Air necessary for combustion: 2 m³/h per kW of installed power - see dataplate.

Power supply voltage 220/240 V 50-60 Hz.



The appliance complies with the following EC Directives:

- 90/396/EEC (Gas);
- 2006/95/EEC (Low Voltage);
- 2004/108 ECC (Electromagnetic Compatibility).